

WELLVENE

InterLift™

[Patent Pending]

wellvene.com





- Volume of equipment
- Structural issues
- Platform resource
- Suspended loads



Equipment Preparation

- Rigging up and down
- Making / breaking toolstrings
- Spading in longer BHA's

InterLift™

Benefits

- Enhances red zone management
- Derisks platform activities



- Tackles operational efficiency
- Challenges deck loading and space inefficiencies

InterLift™

The Package

What Do Wellvene Supply?

Piston lift assy

Bespoke Wireline valve



Lifting clamp

Lubricator c/w insitu connection

Incorporated insitu connection

Incorporated pump in sub



InterLift™

Rig Up

Stage 1.

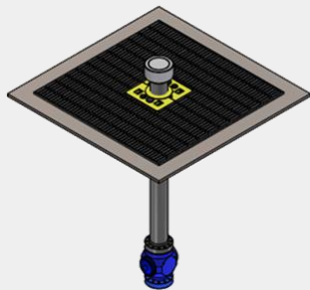

Stage 2.

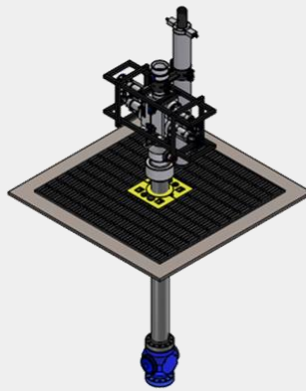

Stage 3.

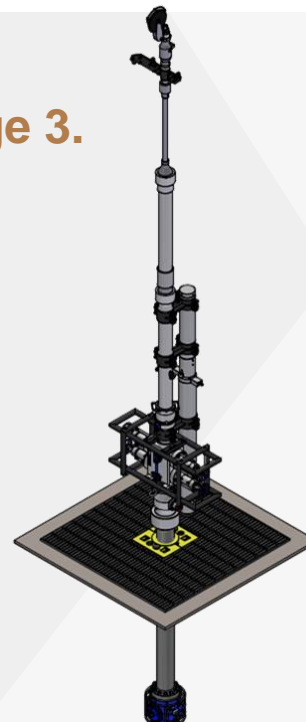

InterLift™

Operational Sequence

- Designed to eliminate working under a suspended load
- Provides automated alignment (stab in/out) of PCE connections
- Enhances red zone management in the offshore industry
- Minimising risks and improving efficiency

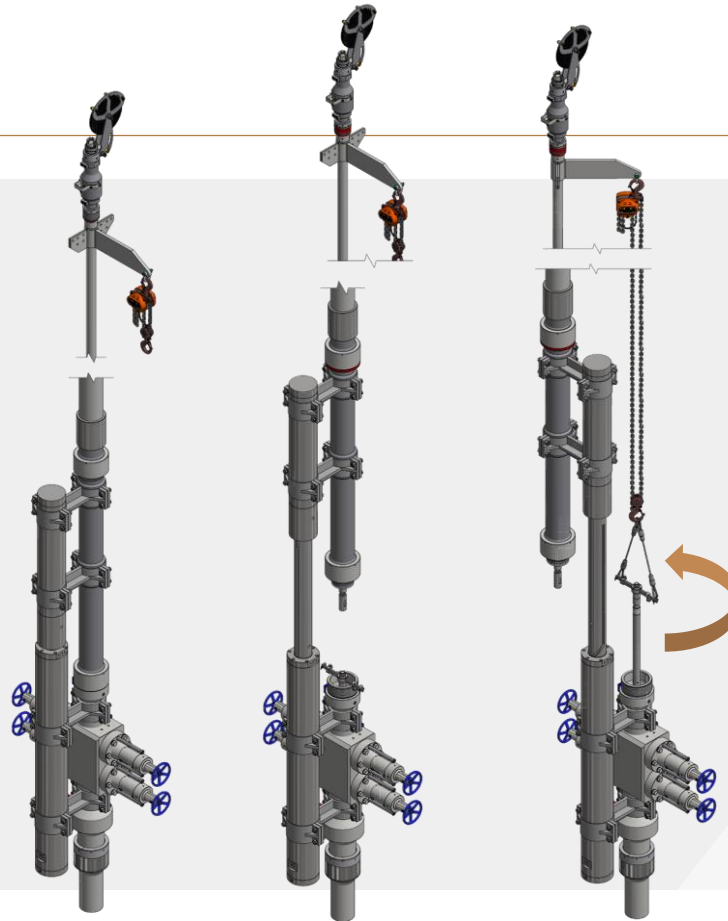

InterLift™

Innovation Through Collaboration



Operations to
date through
the support of
2 key operators

WELLVENE

Designed.
Manufactured.
Qualified.

wellvene.com

